

# Fluid Controls/Accessories

## Locking plunger for key operation

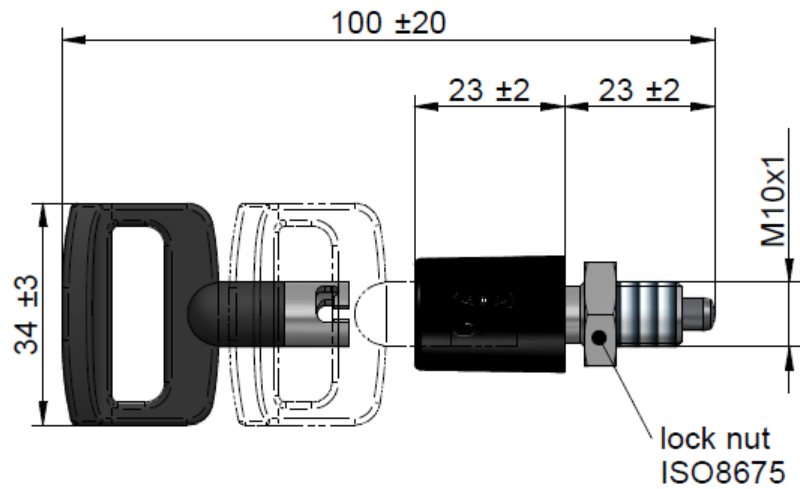

The locking plunger is an optional key operated locking pin for any standard asa shut-off butterfly valve. The high quality stainless steel lock body is a long durable mechanism to prevent any inadvertent operation of the valve. This plunger uses the same thread position as the standard locking pin, for easy retro-fit.



### Technical Data

order number	SDAERASTBELSSK
description	Locking plunger for key operation SS
Threaded body	Stainless steel
Pin	Stainless steel
Spring	Stainless steel
Cap	PA
Key	PA / zinc coated steel*

\*) We recommend to store the key after use in a safe environment, as the metal part of the key has not the same corrosion resistance as the rest of locking plunger.



Please contact us for further information at [support@asahydraulik.com](mailto:support@asahydraulik.com) or online [www.asahydraulik.com](http://www.asahydraulik.com)