



Connection Technology

Suction Line Series

Stainless Steel Series



Suction Line / Stainless Steel Series

Suction Unit SAE 2" to SAE 3" in stainless steel 1.4404



The asa suction unit has been developed to provide a compact unit in hydraulic systems. The asa butterfly flange with SAE connections allows the combination with an elastic element (rubber compensator) to make a short compensating and economical connection with the pump port. The asa suction unit is screwed to the asa adapter flange, which is welded to the tank. Due to low installation costs and compact design, purchasing asa suction units is cost effective. A switch (mechanical or inductive) can be mounted on the standard block for monitoring matters.

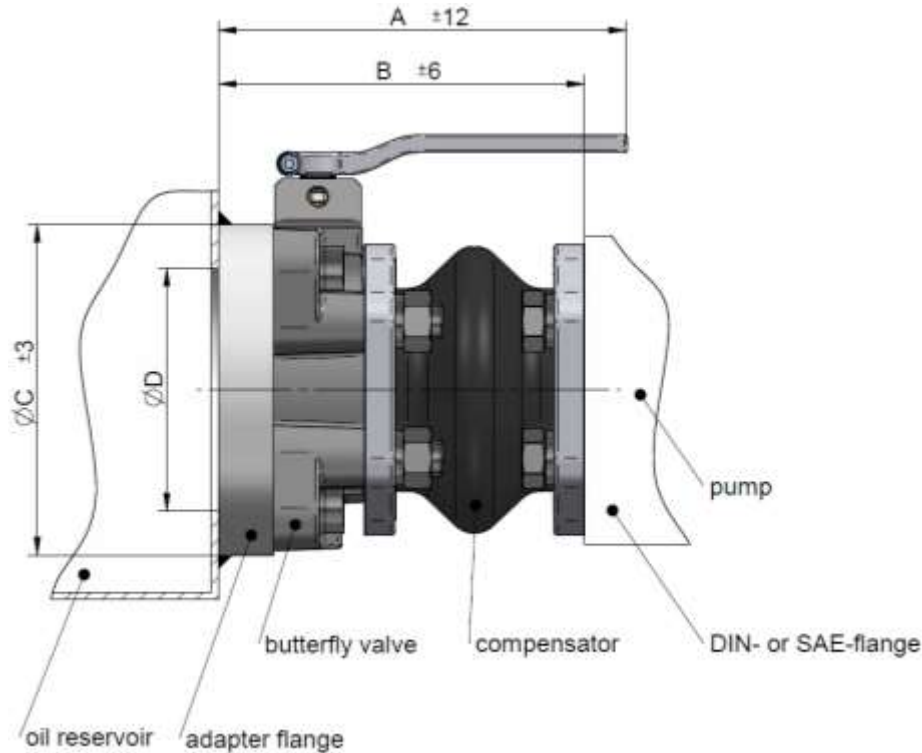

possible valve positions and actuating directions*)

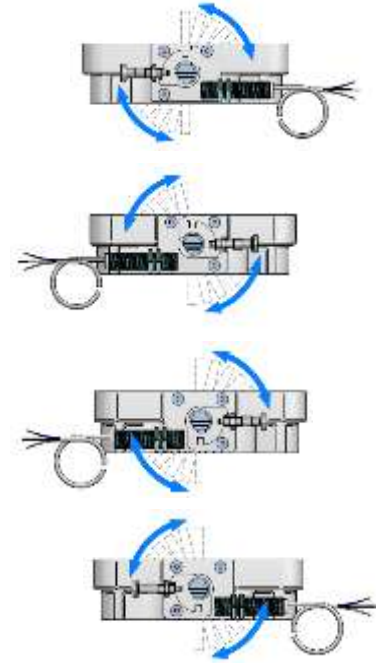

*)...the shown valve is attached with the optional available inductive limit switch. Please contact us to discover all functions and options.

Technical Data

order number	description	size		A	B	C	D	weight
		SAE	DIN					
SDAK0050TSS	ESAF – 50 SS	2"	50	185	168	150	103 ±1	6,15
SDAK0063TSS	ESAF – 63 SS	2 ½"	65	185	165	150	103 ±1	6,36
SDAK0080TSS	ESAF – 80 SS	3"	80	185	166	150	110 ±1	7,88

Working Ranges

working pressure range	0,5-1,5 bar (absolute)
temperature range	-20°C to +80°C

Material

butterfly valve housing	stainless steel 1.4404
valve disc	stainless steel 1.4404
valve sealing	NBR
compensator flange	stainless steel 1.4404
compensator rubber inside	NBR 70 Shore ± 5
compensator rubber outside	CR/NR (Chloroprene/Naturalrubber)
adapter flange	stainless steel 1.4404

Options

locking pin	with key-lock system (page 6)
limit switch	inductive type (page 6)



Please read manual before installation and for the maximum movement tolerances of the rubber connection! Note, that the dimension tolerances have to be taken from the corresponding scale drawing.

This data sheet and the corresponding scale drawings are to be used as a general guideline and technical overview of our products. Please contact us if more exact information is needed. As we are constantly improving our products, their characteristics, dimensions and weights may also change, although we do our best to incorporate these changes continually. asa assumes no liability for any information therein, any errors, omissions, misprints, nor any direct or indirect damages, losses or costs resulting therefrom. Any cooling performances and general technical values indicated in this catalogue are measured at a test bench according to asa testing procedures or calculated, based on such tests. Due to different conditions in testing and application environments the performance may also vary by +/- 15%. Because there is no standardized testing procedure, tests used by other manufacturers could have different results. Therefore we recommend all products to be checked under the system operating conditions. This is also true for vibrations and mechanical stress as well as for pressure peaks and thermal stress and any other relevant factors. General tolerances according to DIN ISO 2768-vL. General tolerances for casted parts according EN ISO 8062-3 (DCTG 10). Tolerances for rubber parts are according to ISO 3302-1 (class M4-F-C). The tolerances of welding seams are defined by quality group D according to EN ISO 10042, if it is not specified on the actual scale drawing or data sheet. In addition to that we point out that any data sheet and corresponding scale drawing is no substitution for the manual.

Suction Line / Stainless Steel Series

Butterfly Valve **SAE 2" to SAE 3" in stainless steel 1.4404**



The asa butterfly flange with SAE and DIN connections allows the combination with an elastic element (rubber compensator) to make a short compensating and economical connection with the pump port. The lever position can be changed through our new mechanism. The handle direction (clockwise or counter clockwise) can be changed by turning the switch bracket. Please note that the butterfly flange may only be opened in mounted state and with greased or lubricated sealing. The adapter flange may only be welded with demounted butterfly flange.

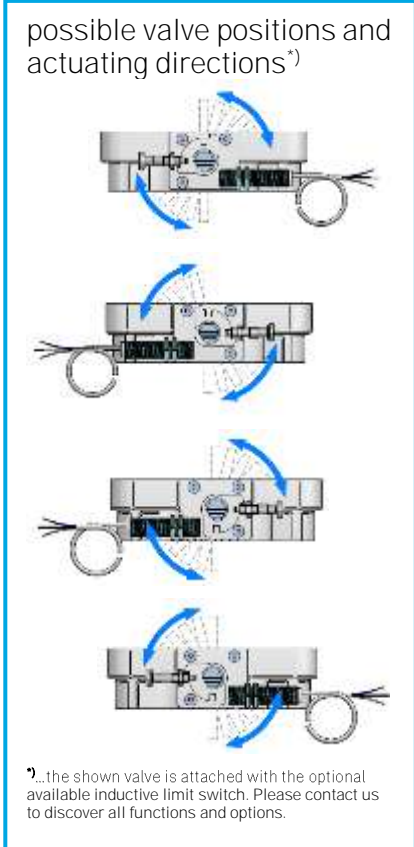
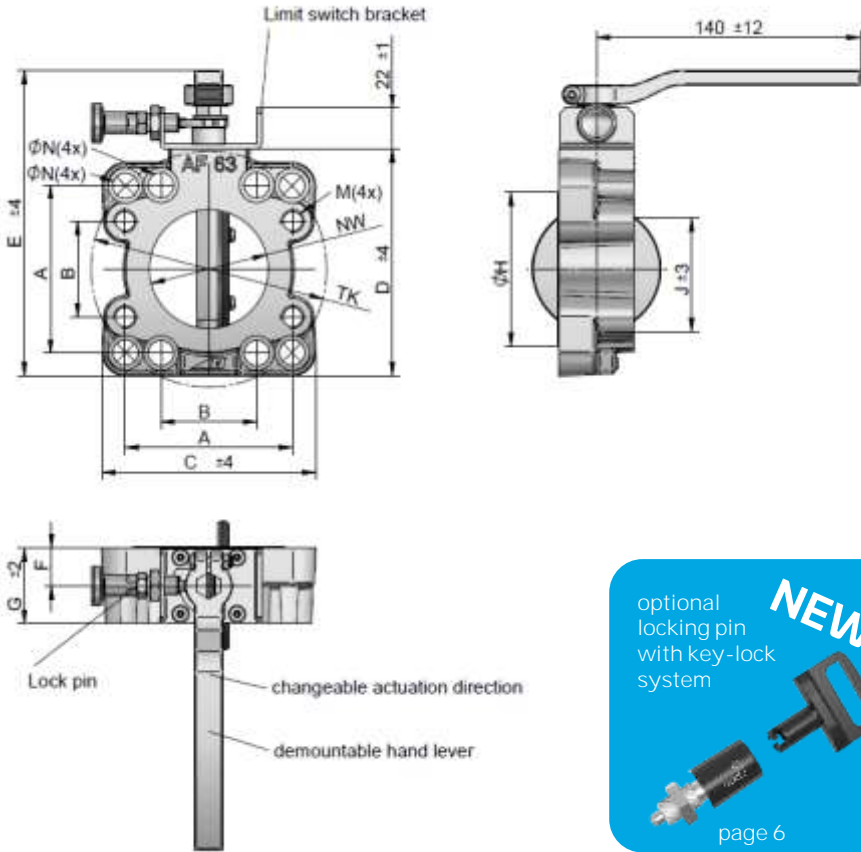

Technical Data

order number	description	size		A	B	C	D	E	F	G	Ø H	J	M	Ø N	NW	TK	weight
		SAE	DIN	[mm]	[mm]	[mm]	[mm]	[mm]	[mm]	[mm]	[mm]	[mm]	[mm]	[mm]	[mm]	[mm]	[kg]
SDA0050SS	AF 50 SS	2"	50	77,8	42,9	111	112	155	20	43	73	27,7	M12	13,5	48	125	2,26
SDA0063SS	AF 63 SS	2 ½"	65	89	50,8	111	119	161	20	40	83	55,3	M12	13,5	63	125	2,30
SDA0080SS	AF 80 SS	3"	80	106,4	62	144	145	187	20	41	95	73,9	M16	18	80	160	3,21

Working Ranges

max. over pressure (open valve)	16 bar
max. differential pressure (closed valve)	6 bar
temperature range	-20°C to +80°C

Materials

housing	stainless steel 1.4404
lever	stainless steel 1.4404
valve disc	stainless steel 1.4404
seals	NBR

Options

locking pin	with key-lock system (page 6)
limit switch	inductive type (page 6)
FPM sealings	contact us for the Viton valve range



This data sheet and the corresponding scale drawings are to be used as a general guideline and technical overview of our products. Please contact us if more exact information is needed. As we are constantly improving our products, their characteristics, dimensions and weights may also change, although we do our best to incorporate these changes continually. asa assumes no liability for any information therein, any errors, omissions, misprints, nor any direct or indirect damages, losses or costs resulting therefrom. Any cooling performances and general technical values indicated in this catalogue are measured at a test bench according to asa testing procedures or calculated, based on such tests. Due to different conditions in testing and application environments the performance may also vary by +/- 15%. Because there is no standardized testing procedure, tests used by other manufacturers could have different results. Therefore we recommend all products to be checked under the system operating conditions. This is also true for vibrations and mechanical stress as well as for pressure peaks and thermal stress and any other relevant factors. General tolerances according to DIN ISO 2768-mS. General tolerances for casted parts according EN ISO 8062-3 (DCTG 10). Tolerances for rubber parts are according to ISO 3302-1 (class M4-F-C). The tolerances of welding seams are defined by quality group D according to EN ISO 10042, if it is not specified on the actual scale drawing or data sheet. In addition to that we point out that any data sheet and corresponding scale drawing is no substitution for the manual.

Suction Line / Stainless Steel Series

Rubber Compensators **SAE 2" to SAE 4"**



Rubber compensators are elastic connectors with turnable SAE flanges. Compensators are used for damping oscillations, vibrations, noises and movements in axial and transversal direction.

Design

Rubber compensators have a plain surface vulcanized to a fabric body (inside and outside) of the rubber part. The outside is weather resistant and protects the fabric against ageing, wear and corrosion. The interior of the rubber part consists of nitril-butadien-caoutchouc (NBR). The outer layer is made of CR/NR (Chloroprene/Naturalrubber). Because compensators have tightening lips on both sides, further seals are not necessary.

Use

Standardized mineral oil products (except synthetic oils), crude oil, lubrication oil, cooling oil (-20°C up to 80°C), grease (mineral), cold water, warm water up to 60°C, water/oil emulsions, fuel with 30% aromatic content.

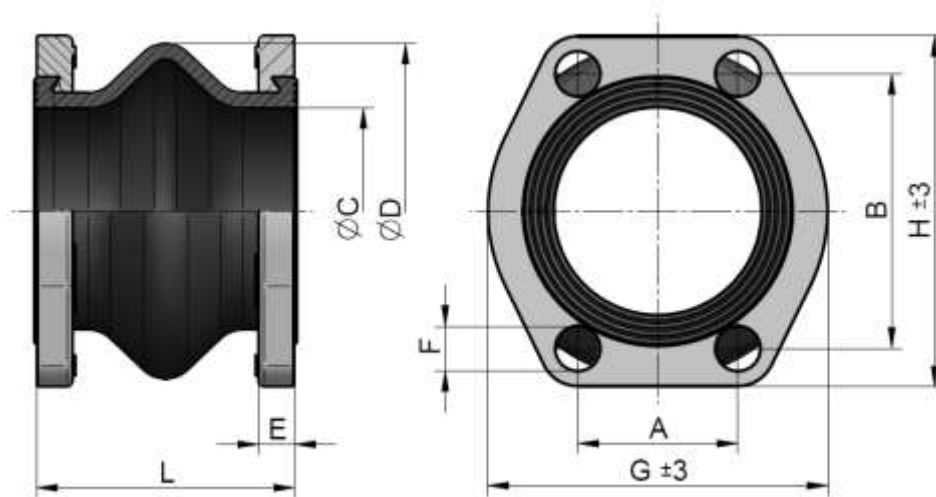

order number	description	size		A	B	C	D	E	F	G	H	L	weight [kg]
		SAE	NG*	[mm]	[mm]	[mm]	[mm]	[mm]	[mm]	[mm]	[mm]	[mm]	
SDKSS050SS	K16S – 50 SS	2"	50	42,9	77,8	48 ^{+1/-3}	96±2	13	13	97	103	100±4	1,02
SDKSS063SS	K16S – 63 SS	2 ½"	63	50,8	89,0	63 ^{+1/-3}	111±2,5	14	13	109	115	100±4	1,25
SDKSS080SS	K16S – 80 SS	3"	80	62,0	106,4	80 ^{+1/-3}	130±2,5	14	17	131	136	100±4	1,74
SDKSS100SS	K16S – 100 SS	4"	100	77,8	130,2	100 ^{+1/-3}	150±2,5	16	17	152	162	100±4	2,51

*... NG = nominal size

Working Pressure

maximum working pressure	NG50 to NG80 0,5-1,5 bar (absolute) NG100 0,7-1,5 bar (absolute)
temperature range	-20°C to +80°C

Material

inside	NBR 70 shore ± 5
outside	CR/NR ((Chloroprene/Naturalrubber)
flange	stainless steel 1.4404

Option

sizes SAE1", SAE1 ¼", SAE1½, SAE3½, SAE5" on request
--



Please read manual before installation and for the maximum movement tolerances of the rubber connection! Note, that the dimension tolerances have to be taken from the corresponding scale drawing.

This data sheet and the corresponding scale drawings are to be used as a general guideline and technical overview of our products. Please contact us if more exact information is needed. As we are constantly improving our products, their characteristics, dimensions and weights may also change, although we do our best to incorporate these changes continually. asa assumes no liability for any information therein, any errors, omissions, misprints, nor any direct or indirect damages, losses or costs resulting therefrom. Any cooling performances and general technical values indicated in this catalogue are measured at a test bench according to asa testing procedures or calculated, based on such tests. Due to different conditions in testing and application environments the performance may also vary by +/- 15%. Because there is no standardized testing procedure, tests used by other manufacturers could have different results. Therefore we recommend all products to be checked under the system operating conditions. This is also true for vibrations and mechanical stress as well as for pressure peaks and thermal stress and any other relevant factors. General tolerances according to DIN ISO 2768-vL. General tolerances for casted parts according EN ISO 8062-3 (DCTG 10). Tolerances for rubber parts are according to ISO 3302-1 (class M4-F-C). The tolerances of welding seams are defined by quality group D according to EN ISO 10042, if it is not specified on the actual scale drawing or data sheet. In addition to that we point out that any data sheet and corresponding scale drawing is no substitution for the manual.

Suction Line / Stainless Steel Series

Adapter Flanges in stainless steel 1.4404



The **asa** suction unit is screwed to the **asa** adapter flange, which is welded to the tank. Due to low installation costs and compact design, purchasing asa suction units is cost effective. A switch (mechanical or inductive) can be mounted on the standard block for monitoring matters. The adapter flange may only be welded with demounted butterfly flange.

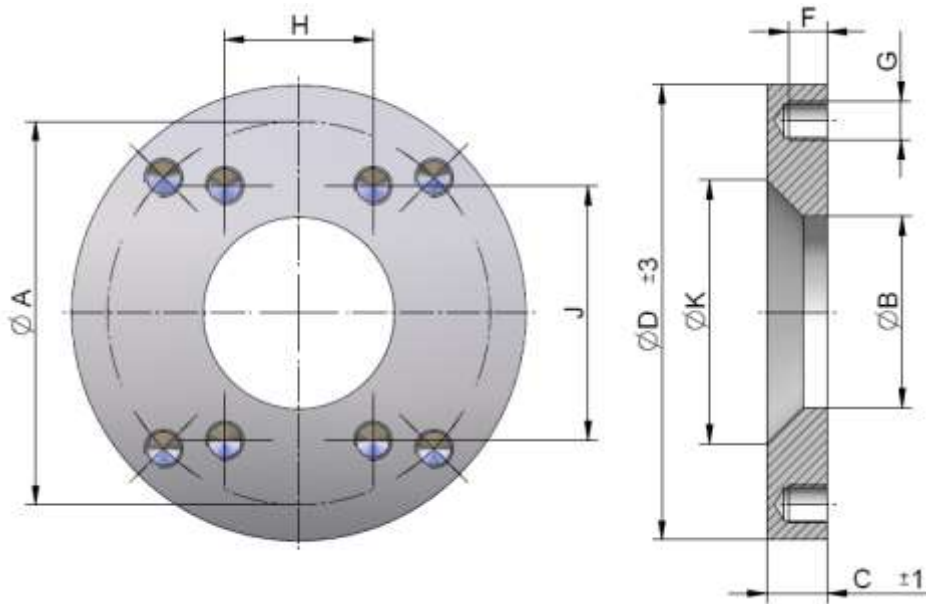

order number	description	A	B	C	D	F	G	H	J	K	weight
		[mm]	[mm]	[mm]	[mm]	[mm]	[mm]	[mm]	[mm]	[mm]	[kg]
SDAET063SSK	Adapter 50 & 63 SS	125	63	25	150	16	M12 (4x)	--	--	103 ±1	2,5
SDAET080SSK	Adapter 80 SS	--	82	25	150	14	M16 (4x)	62	106,4	109 ±1	2,2
SDAET100SSK	Adapter 100 SS	--	100	25	180	14	M16 (4x)	77,8	130	139 ±1	2,8

Material

flange material	stainless steel 1.4404
-----------------	------------------------

Fits On

SDAET063SSK	SDA0050SS, SDA0063SS
SDAET080SSK	SDA0080SS



This data sheet and the corresponding scale drawings are to be used as a general guideline and technical overview of our products. Please contact us if more exact information is needed. As we are constantly improving our products, their characteristics, dimensions and weights may also change, although we do our best to incorporate these changes continually. asa assumes no liability for any information therein, any errors, omissions, misprints, nor any direct or indirect damages, losses or costs resulting therefrom. Any cooling performances and general technical values indicated in this catalogue are measured at a test bench according to asa testing procedures or calculated, based on such tests. Due to different conditions in testing and application environments the performance may also vary by +/- 15%. Because there is no standardized testing procedure, tests used by other manufacturers could have different results. Therefore we recommend all products to be checked under the system operating conditions. This is also true for vibrations and mechanical stress as well as for pressure peaks and thermal stress and any other relevant factors. General tolerances according to DIN ISO 2768-vL. General tolerances for casted parts according to EN ISO 8062-3 (DCTG 10). Tolerances for rubber parts are according to ISO 3302-1 (class M4-F-C). The tolerances of welding seams are defined by quality group D according to EN ISO 10042, if it is not specified on the actual scale drawing or data sheet. In addition to that we point out that any data sheet and corresponding scale drawing is no substitution for the manual.

Suction Line / Stainless Steel Series

Accessories



Inductive Limit Switch

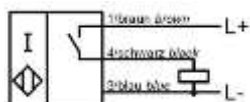
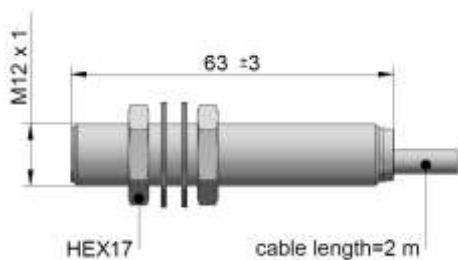

order number	EAFS1SSK
description	Inductive switch SS
Operating voltage	10...30 VDC
Rated operating current	200 mA
Switching frequency	3500 Hz
Switching output	PNP normally open (NO)
Rated operating distance	2 mm
Conductor cross-section	0,34 mm ²
Installation	for flush mounting
Size	M12x1
Tightening torque	12 Nm
Protection degree	IP68
Ambient temperature	-40...85 °C
Housing material	Stainless steel

Locking plunger for key operation

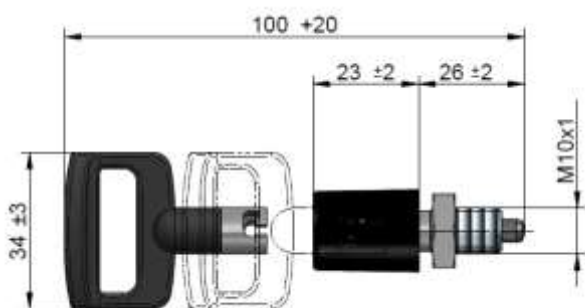

order number	SDAERASTBELSSK
description	Locking plunger for key operation SS
Threaded body	Stainless steel
Pin	Stainless steel
Spring	Stainless steel
Cap	PA
Key	PA / zinc coated steel*

*) We recommend to store the key after use in a safe environment, as the metal part of the key has not the same corrosion resistance as the rest of locking plunger.

Please contact us for further information at support@asahydraulik.com or online www.asahydraulik.com

This data sheet and the corresponding scale drawings are to be used as a general guideline and technical overview of our products. Please contact us if more exact information is needed. As we are constantly improving our products, their characteristics, dimensions and weights may also change, although we do our best to incorporate these changes continually. asa assumes no liability for any information therein, any errors, omissions, misprints, nor any direct or indirect damages, losses or costs resulting therefrom. Any cooling performances and general technical values indicated in this catalogue may also vary by +/- 15%. Because there is no standardized testing procedure, tests used by other manufacturers could have different results. Therefore we recommend all products to be checked under the system operating conditions. This is also true for vibrations and mechanical stress as well as for pressure peaks and thermal stress and any other relevant factors. General tolerances according to DIN ISO 2768-vL. General tolerances for casted parts according EN ISO 8062-3 (DCTG 10). Tolerances for rubber parts are according to ISO 3302-1 (class M4-F-C). The tolerances of welding seams are defined by quality group D according to EN ISO 10042, if it is not specified on the actual scale drawing or data sheet. In addition to that we point out that any data sheet and corresponding scale drawing is no substitution for the manual.

Suction Line / Stainless Steel Series

Complementary Stainless Steel Products



High Pressure Compensators

The asa high pressure compensator series is carried out as high performance design with very flexible capabilities and long duration. It's high shape design focusses most compact flange to flange dimension and excellent noise reduction and vibration absorption as well as high movement tolerances in all directions.

The sealing part of the rubber is designed to seal without any additional sealing material. The turnable metal flanges are designed with a flare to support the pressure performance of the product. This is a major difference to other solutions in the market with direct impact to the high duration of the compensator.

General specification

Working pressure	16 bar *
Sizes	32 to 300
Flange Type	DIN flange PN16
Flange material	Stainless steel on request
Rubber material	NBR/CR/NR

*) More information can be from the corresponding data sheet.



Rubber Vibration Absorber

The asa rubber vibration absorbers are rubber metal connected parts to absorb impact loads on components as protection and to extend the life time. The patented solution is especially equipped for highest shear loads. An assembly system controlled by arrows on the metal parts helps to optimize and raise the load capability of the vibration absorber.

General specification

Order number	MDGQ4030081 I W
Description	40x40x30 M8
Material	stainless steel 1.4301
Elastomer	NR, black, 45shore
Max.shear load	950N



This data sheet and the corresponding scale drawings are to be used as a general guideline and technical overview of our products. Please contact us if more exact information is needed. As we are constantly improving our products, their characteristics, dimensions and weights may also change, although we do our best to incorporate these changes continually. asa assumes no liability for any information therein, any errors, omissions, misprints, nor any direct or indirect damages, losses or costs resulting therefrom. Any cooling performances and general technical values indicated in this catalogue are measured at a test bench according to asa testing procedures or calculated, based on such tests. Due to different conditions in testing and application environments the performance may also vary by +/- 15%. Because there is no standardized testing procedure, tests used by other manufacturers could have different results. Therefore we recommend all products to be checked under the system operating conditions. This is also true for vibrations and mechanical stress as well as for pressure peaks and thermal stress and any other relevant factors. General tolerances according to DIN ISO 2768-vL. General tolerances for casted parts according EN ISO 8062-3 (DCTG 10). Tolerances for rubber parts are according to ISO 3302-1 (class M4-F-C). The tolerances of welding seams are defined by quality group D according to EN ISO 10042, if it is not specified on the actual scale drawing or data sheet. In addition to that we point out that any data sheet and corresponding scale drawing is no substitution for the manual.



Thermal Systems
Connection Technology
Fluid Controls

be different.
make a difference.

AUSTRIA

asa technology GmbH
Prager Strasse 280
A-1210, Vienna
Tel.: +43 1 292 40 20
support@asahydraulik.com

USA

asa hydraulik of America
160 Meister Avenue 20 A
Branchburg, New Jersey 08876
Tel.: +1 800 473 94 00
Tel.: +1 908 541 15 00
sales_us@asahydraulik.com

CHINA

安飒液压科技（苏州）有限公司
asa Hydraulik Technology (Suzhou) Co.Ltd
江苏省苏州市工业园区方洲路128号6区B幢
Area 6, Building B,
Fangzhou Road No 128,
Suzhou industrial park,
Suzhou City, Jiangsu Province
Tel.: +86 512 62381988
suzhou@asahydraulik.com

AUSTRALIA

asa Products Pty Ltd
Quinlan Road 23
3076 Epping, Victoria
Tel.: +61 3 9397 6129
melbourne@asahydraulik.com

INDIA

ASAhdraulik India Pvt Ltd
Pot No.1226, Phase-3, G.I.D.C Vatva
Ahmedabad - 382445
Tel.: +91 22 28195557
salesindia@asahydraulik.com

