

Product Description

The asa water pump is working to the centrifugal principle and uses a spiral housing with 1" or 3/4" hose connections, magnet coupling 12V DC brushless motor. The motor and the coupling are installed in an aluminium die cast housing. This motor/pump unit is mainly designed to create compact and cost efficient cooling circuits for electric devices such as battery packs, electric motors and power electronics like converters.

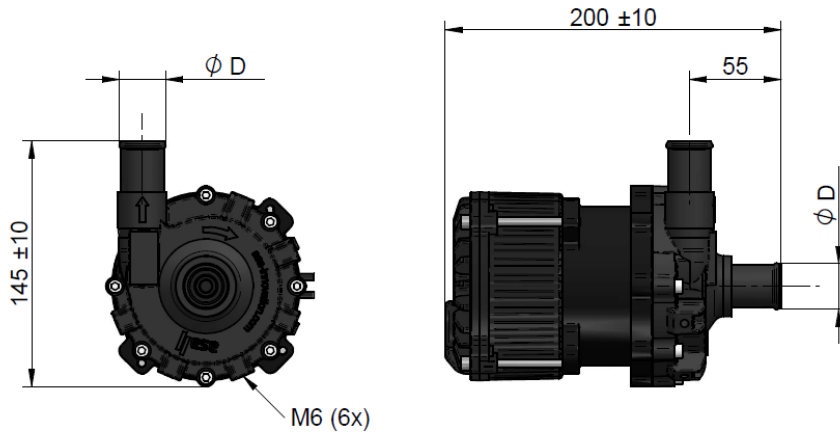

**Pump Connector:
Delphi Metri Pack
150/480 7 Way
Sealed Male Connector**

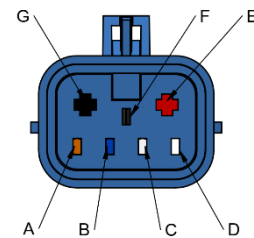

PIN	color	function
A	orange	reserved, not used
B	blue	PWM input
C	white	fault feedback output
D	-	-
E	red	12V
F	-	-
G	Black	GND

Technical Data

order number	description	fuse	protection	flow rate	motor type	ØD	weight
		[A]		[l/min]			[kg]
ABPW090S20HP01K	Water pump 90 l/min 3/4" 12V HNBR	35	IP68	see chart page 3	brushless	3/4"	3,2
ABPW090S25HP01K	Water pump 90 l/min 1" 12V HNBR	35	IP68			1"	3,2

Specification

operating supply voltage range	9-16V
max. current	31A
housing an cover material	aluminium
sealing material (fluid side)	HNBR
working temperature range	-20°C to +120°C (pump flow derated between +85°C and +120°C)

Safety process / Diagnostic output

Duty cycle:	Definition:
40%	Pump is running dry
50%	Over current
70%	Over temperature
80%	Under- and Over voltage
100%	No error

Features

adjustable flow rate	PWM signal
diagnostic output	PWM signal
medium to be pumped	water & water-glycol

Connector Counterpart kit

connector type	Delphi Metri Pack (optional mating connector order number: ESMPWP12K)
----------------	---

Type Approval

KBA (E1) 10R-05 9582 01



1.) Mounting option B00

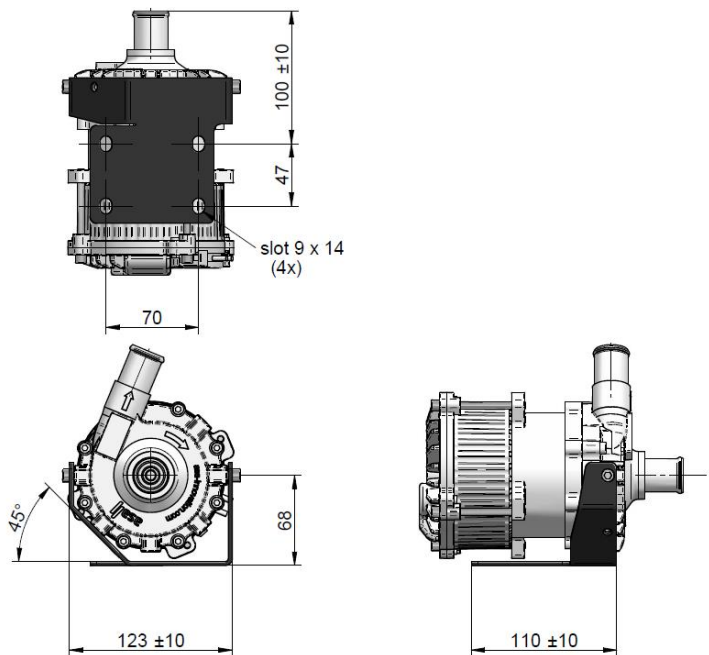

2.) Mounting option B01

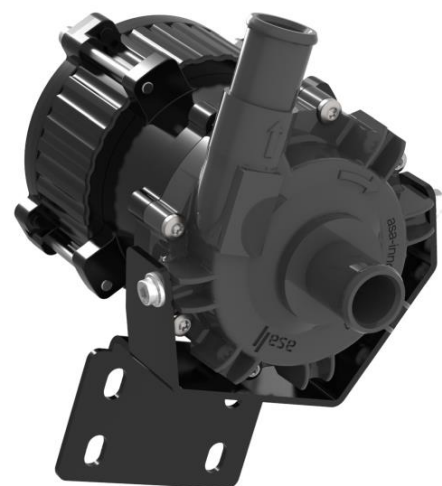
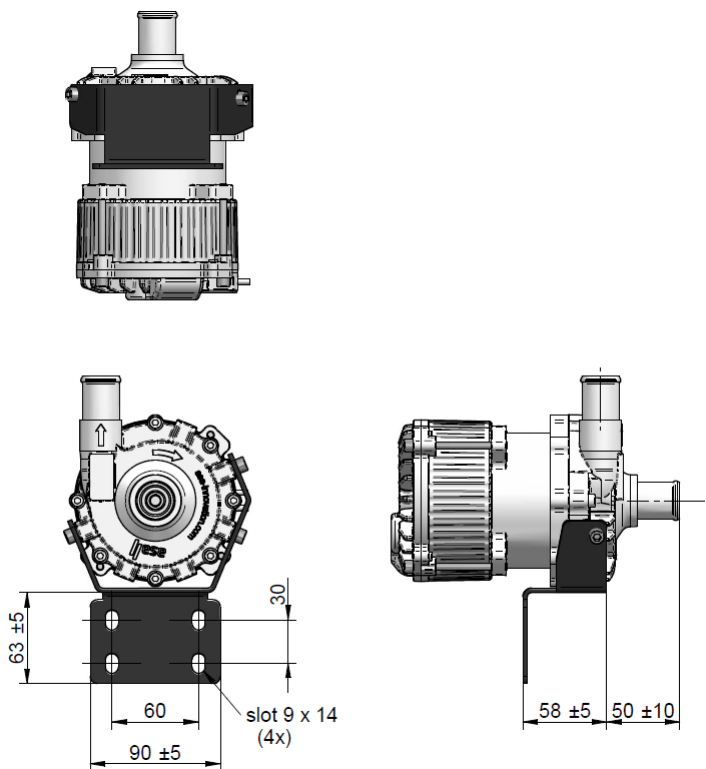

Order Code

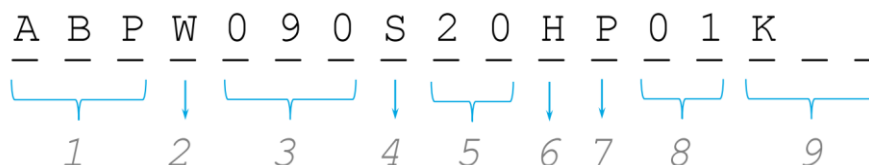

1 Product Category

ABP Pumps

2 Product Series

W Water pump

3 Displacement volume

090 90 l/min

4 Connection

S standard motor/pump

5 Dimensions

20 3/4"

25 1"

6 Sealing Material (medium side)

H HNBR

E EPDM (on request)

V FPM(Viton) (on request)

7 Control

P PWM

8 Voltage

01 12 V

9 Index / Customized

K standard sales kit

B00 mounting option picture 1

B01 mounting option picture 2

BXX special / customized specifications; to be advised by asa

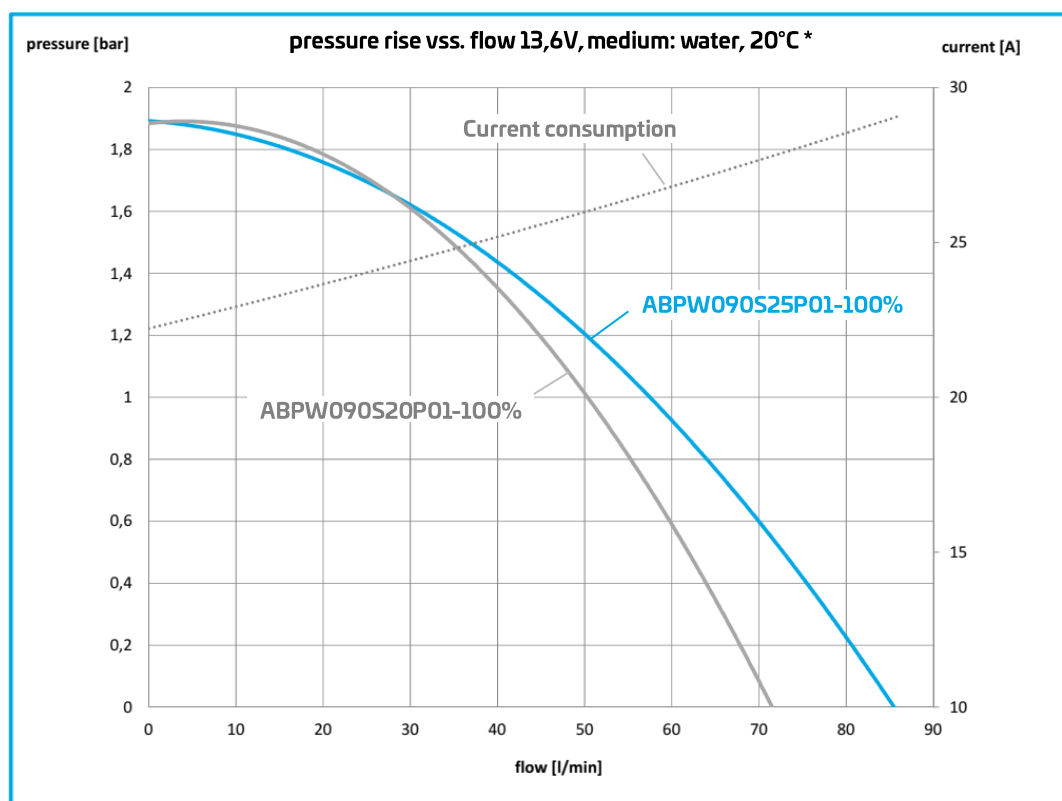

*) Tested and verified according asa standards on asa bench.